

TP 230 PTO

A strong wood chipper for chipping wood of up to 230 mm in diameter with trailer coupling. A disc chipper with hydraulic feeding and with the funnel 90 degrees to the side. The vertical feed rollers and the cutting angle of 45 degrees ensure an aggressive and problem free chipping of even the most crooked trunks. TP 230 is the obvious wood chipper when you want to collect the chips in a cart.

At the same time, the perpendicular chipper gives great advantages when the material to be chipped is placed alongside a road. Effect need from 50 to 120 hp.

Standard on TP 230

- Integrated hydraulics system
- Three knives
- Three sliver breakers type A
- Two anvils in Hardox 400
- Two hydraulically powered feed rollers which ensure a powerful feeding
- Two Powerful tension springs on moving roller
- Revolving ejector spout
- Wipers to ensure against accumulation of material in the rotor housing
- Changeable casing in rotor housing
- Hydraulic adjustment of the roller speed
- Rotor lock for securing the rotor disc when changing knives
- Trailer hitch
- Danfoss Hydraulic engines
- Tip-up funnel - right angled to the driving direction
- Comprehensive manual with complete spare parts list



TP 100

TP 150

TP 200

TP 250

TP 230

TP 270

TP 280

TP 400

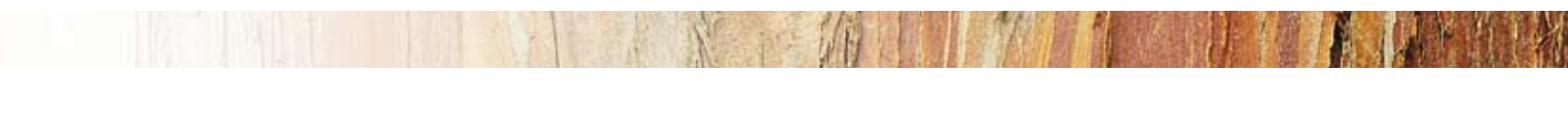

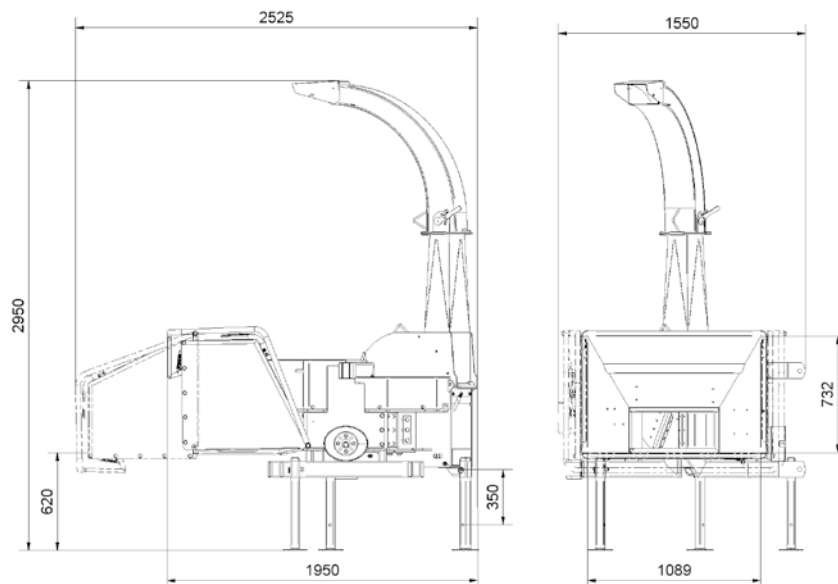

TECHNICAL DATA

Max wood diameter	230 mm
Max opening	H x W = 230 x 240 mm
Operation	Return/forward/stop of feed rollers through operating bar (yellow)
Chipper principle	Disc
In feed angle	45°
Feeding angle	Perpendicular to driving direction
In feed	2 hydraulic feed rollers, spring compressed of 1 spring 8 mm
Feed rollers	Horisontal
Rotordisc - diameter	760 mm
Rotordisc - Weight in kg	149
Number of knives	3 pcs.
Chip lenght	12-19 mm
Anvil/Counter steel	1 horisontal and 1 vertical
Power required	37-90 kW (50-120 hp)
PTO rpm	540 rpm or 1.000 rpm/min.
PTO shaft	Walterscheid 2400 series with freewheel, length = 560 mm
3-point linkage	Category 2
Chip capacity	10-15 m ³ /hour (Experience numbers by manuel operation)
Max allowable pressure on coupling	500 kg
Weight	990 kg

EXTRA EQUIPMENT

Stress control system	For protections of the engine of the tractor by monitoring the rpm on the rotor disc
Extended ejector spout	500 mm vertical • 1.500 mm horisontal
Tip-up ejector spout	
Sliverbreakers	Type B - are used if extra requirements for chip quality is needed Opening max. 35x40 mm
TP Winch	For wood feeding - the winch is towed by the wood chippers hydraulic system
Light bar	Light bar with complete set of rear lights
Tool kit	Includes tools for daily service and maintenance